

1.2. Características técnicas básicas / Basic Specifications

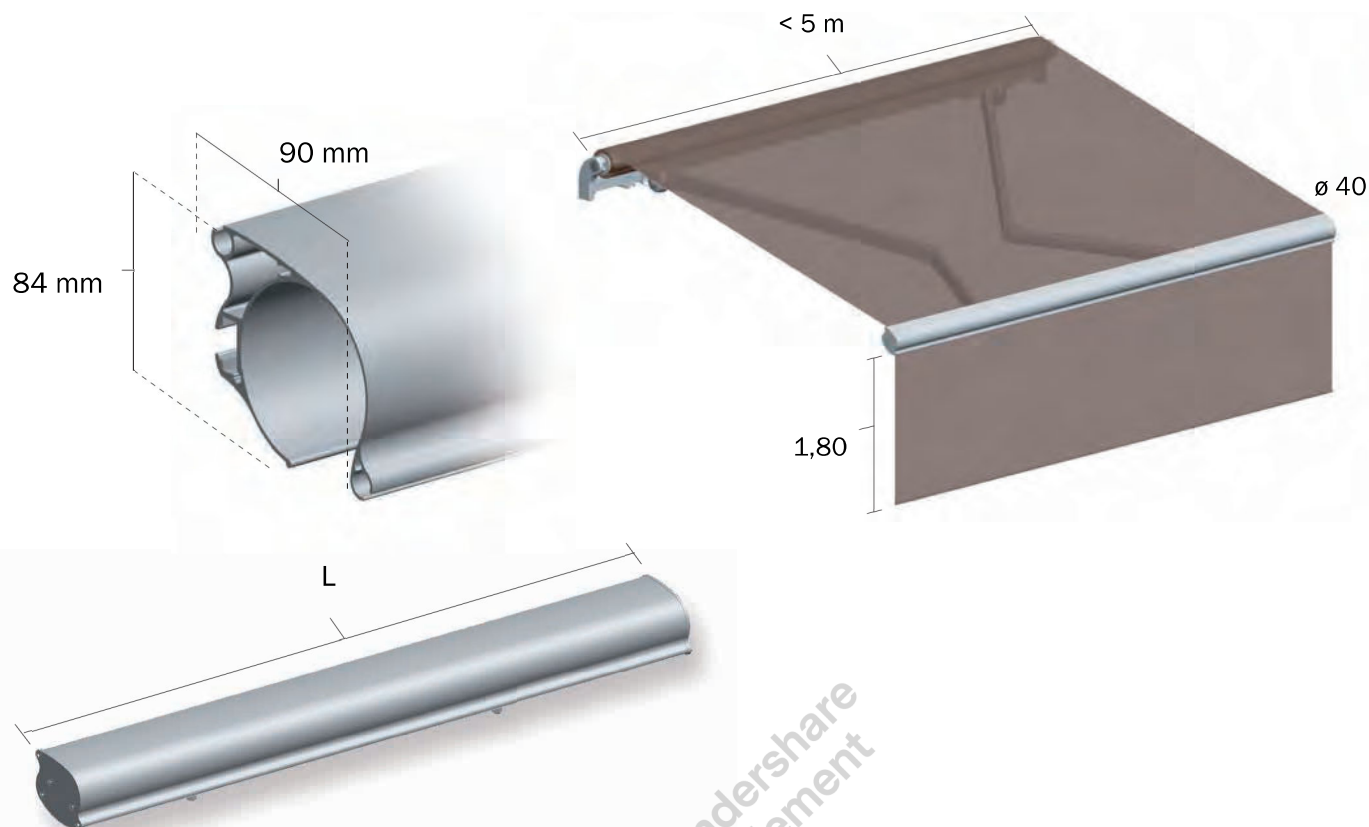

Corte de perfiles / Allowances for profiles and fabric (mm)

	Máquina t. enrollado $\varnothing 40$ Gearbox Rolling tube $\varnothing 40$	Máquina t. enrollado $\varnothing 50$ Gearbox Rolling tube $\varnothing 50$	Motor $\varnothing 40$	
			T. enrollado $\varnothing 40$ $\varnothing 40$ R. tube	T. enrollado $\varnothing 50$ $\varnothing 50$ R. tube
Tubo de enrollado Rolling tube	L-75	L-80	L-65	L-70
Tejido Fabric	L-80	L-85	L-70	L-75

Salida máxima Sombrex 500 / Sombrex 500 maximum projection

Tipo de brazos Type of arm	Línea Width	Salida máxima Maximum projection
ART 350	< 4 m.	3,00 m.
SPLENDOR 400 ONYX - ONYX	De 4 a 5 m From 4 to 5 m.	2,75 m.

Acabados / Finishes

Lacado según normativa QUALICOAT
Lacquer in accordance with QUALICOAT standards

Tornillería de acero inoxidable
Stainless steel screws and bolts

Acionamiento / Operation

Manual

Motorizado / Motorised
 $\varnothing 40$: 8Nm // $\varnothing 50$: 15Nm

Instalação / Installation

Permite su instalación con los modelos de Brazos ART 350 / SPLENDOR 400

Can be installed with ART 350 arms and SPLENDOR 400 arms.

Capacidade máxima de enrollado / Maximum rolling capacity
SOMBREX 500 \varnothing 50: 1,20m. \varnothing 40: 1,80 m.